

Each clock source can be switched on or off independently when it is not used, to optimize power consumption.

Figure 16. Clock tree

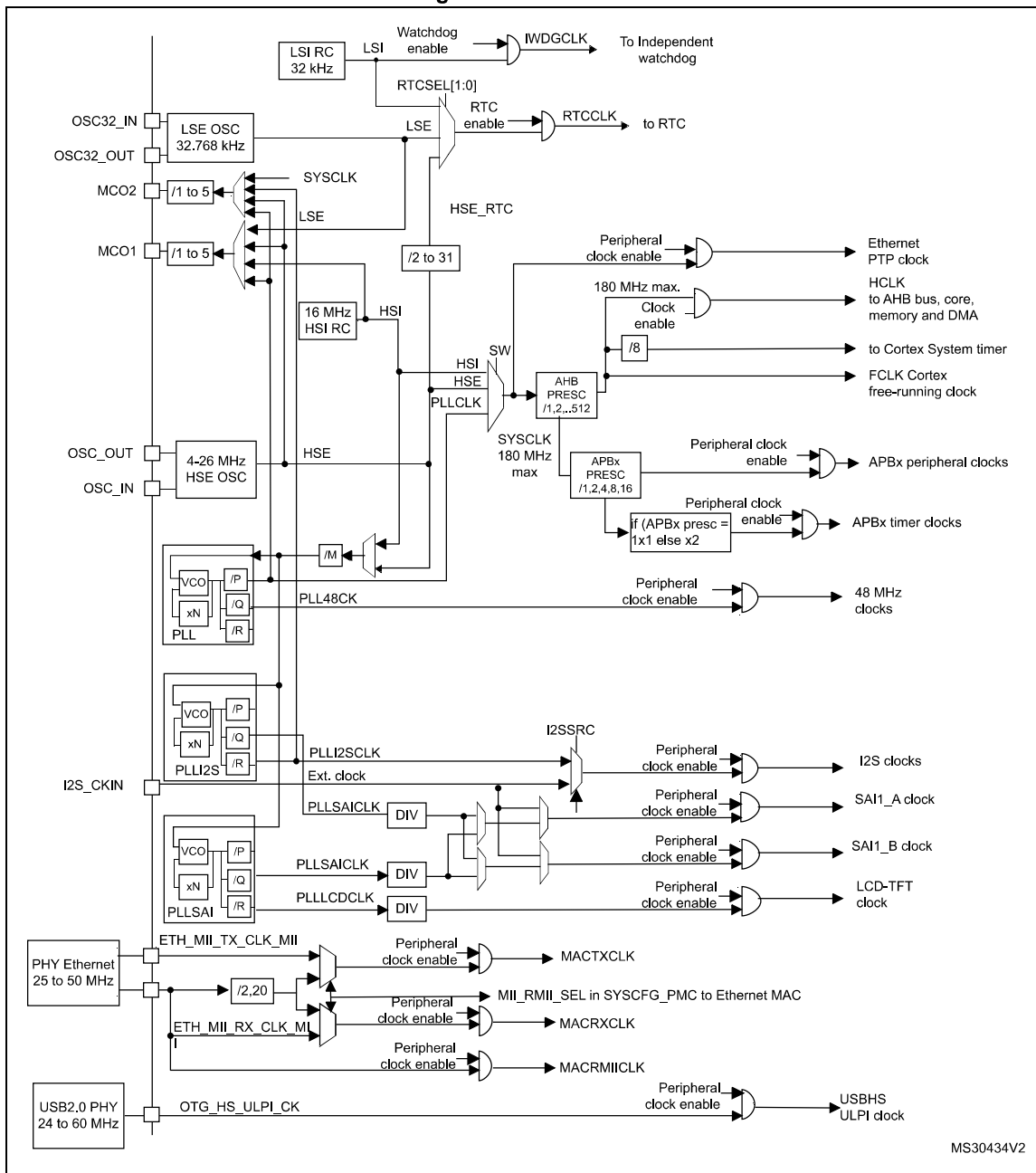

1. For full details about the internal and external clock source characteristics, refer to the Electrical characteristics section in the device datasheet.
2. When TIMPRE bit of the RCC_DCKCFGR register is reset, if APBx prescaler is 1, then TIMxCLK = PCLKx, otherwise TIMxCLK = 2x PCLKx.
3. When TIMPRE bit in the RCC_DCKCFGR register is set, if APBx prescaler is 1,2 or 4, then TIMxCLK = HCLK, otherwise TIMxCLK = 4x PCLKx.