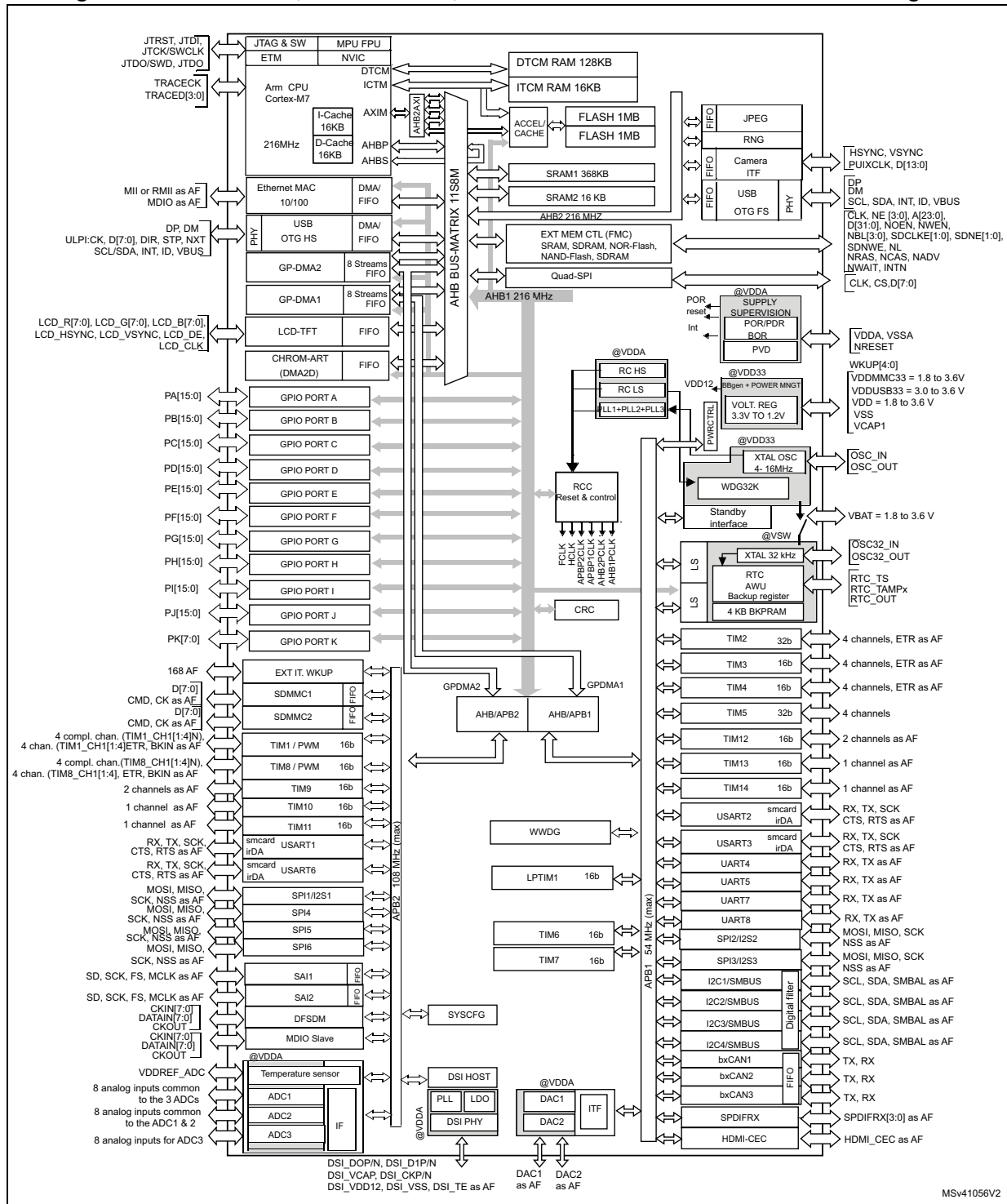

Figure 2. STM32F765xx, STM32F767xx, STM32F768Ax and STM32F769xx block diagram



1. The timers connected to APB2 are clocked from TIMxCLK up to 216 MHz, while the timers connected to APB1 are clocked from TIMxCLK either up to 108 MHz or 216 MHz depending on TIMPRE bit configuration in the RCC_DCKCFGR register.